

HIGH DENSITY SEED DRILL



HDX: HIGH DENSITY SEED DRILL

Stanhay's HDX is a modular high density seed drill. It utilises a sponge metering system to deliver accurate high rate application of a variety of small seed types alongside a chassis and coulter system to ensure even depth and seed coverage across the width of the bed for ultimate uniformity of the crop in a variety of ground conditions.

3 HDX

Just some of the seeds you can handle are listed below:

- Lettuce
- Wild Rocket
- Spinach
- Valerian
- Bok Choy
- Japanese Mustard
- Basil
- Coriander
- Parsley
- Chicory
- Dill
- Red Chard
- Black Cabbage



THE METERING UNIT

A robust and versatile sponge metering unit ideally suited to accurate rate applications of high density crops.

SPONGE TYPES	SEEDS
117	Seeds like Red Chard at high rates 200kg/Ha+
120	Large Seeds such as Spinach, Beets, Corriander
126	Small Seeds such as Rocket, Baby Leaf, Chicory and Parsley
122 / 124	Seeds like Lamb's Lettuce

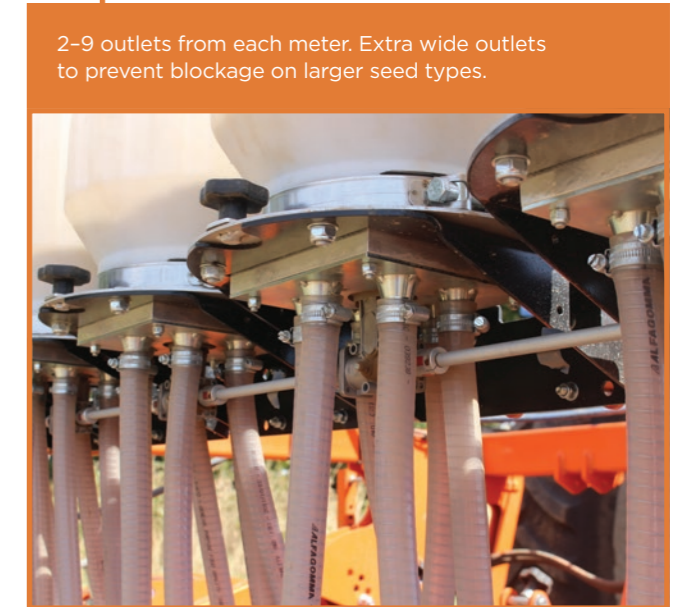

THE ROW UNIT



Single pipe delivery into the soil to prevent changes of diameter and potential seed blockage. Space for a second feed into coulter for increased rate or additional product.

Infinitely adjustable coulter depth control over 90mm range.

Downforce reducing spring system.

Row unit latch up system.

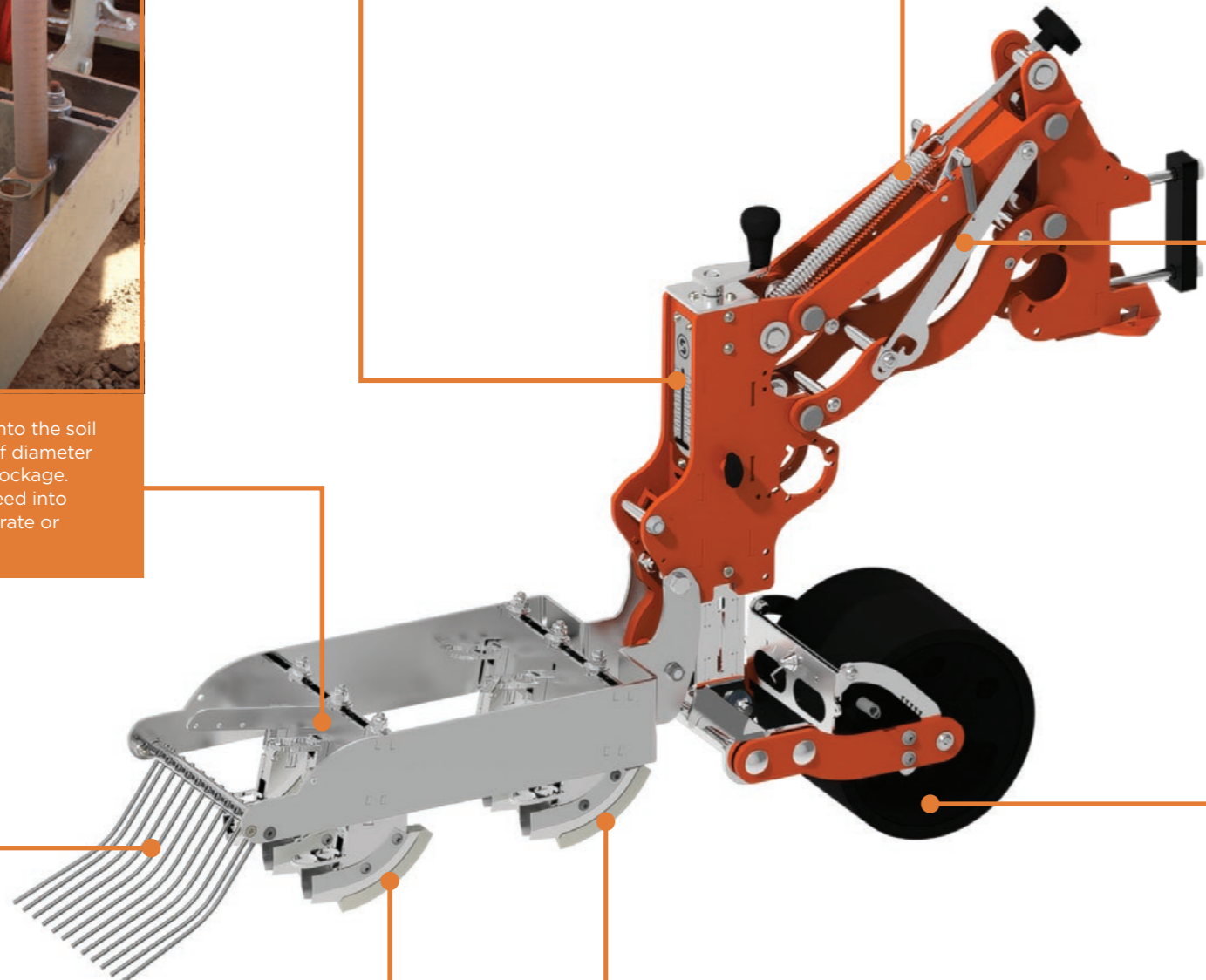

Closing rear rake system.



Choice of reversible cast or ceramic coulter tips.



Adjustable coulter spacings in tandem formation for easy soil flow.

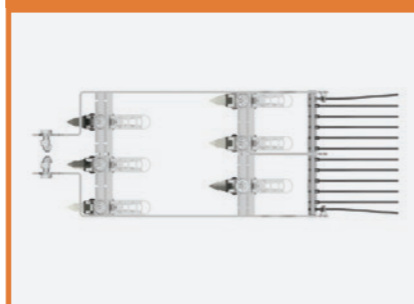

Wide choice of row unit wheels.



Central electric motor drive can power up to 8 seed meters and keeps rate constant regardless of forward speed

Access step for easy filling

Frame depth wheels to set toolbar height

Range of full width roller system available to leave a flat bed top

Rear roller scraper



RIGID & FOLDING TOOLBARS

A variety of rigid and folding toolbars can be supplied to suit any machine layout from 2m to 9m+.

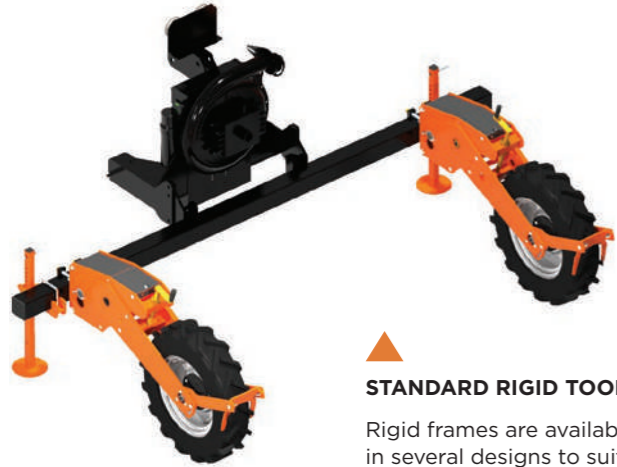

STANDARD RIGID TOOLBARS

Rigid frames are available in several designs to suit machine requirements and are highly customizable to suit machine layouts and additional equipment requirements.



UNIVERSAL FOLDING FRAME

A robust and versatile folding frame with adjustable toolbars lengths to suit a variety of machine layouts and widths. The frame can be selected with fixed or floating wings to maximise ground contour following ability. It allows the working width of the machine to be halved for road transport and comes complete with an automatic frame locking system for safe road transport.

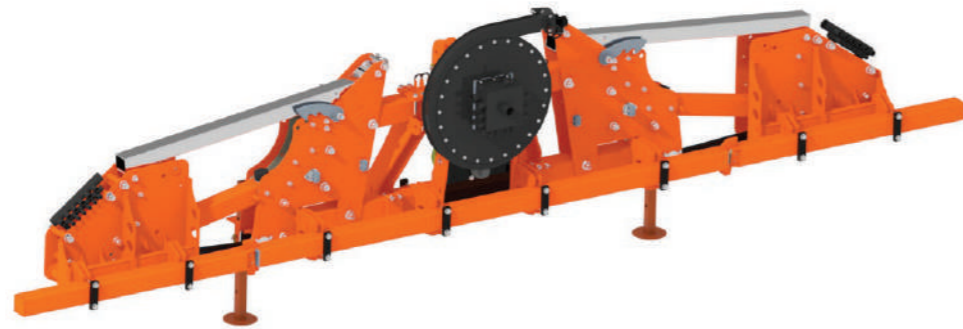

LADDER FRAMES

A double toolbar rigid frame suitable for larger drills up to 9m in width. This frame can be customised to suit bespoke machines and is capable of being fitted with multiple fans if required.



All machines can be equipped with full road lighting.

APPLICATOR SOLUTIONS

Stanhay can make provision to fit most aftermarket chemical or fertiliser applicator systems with different mounting brackets. Placement of the product can be achieved with our own fishtail or straight fertiliser outlets at the coulter or mounting systems can be added to suit most other aftermarket systems.

GRAVITY FED APPLICATORS

Most aftermarket gravity fed fertiliser applicators can be fitted onto our universal mounting brackets which are totally adjustable in position.

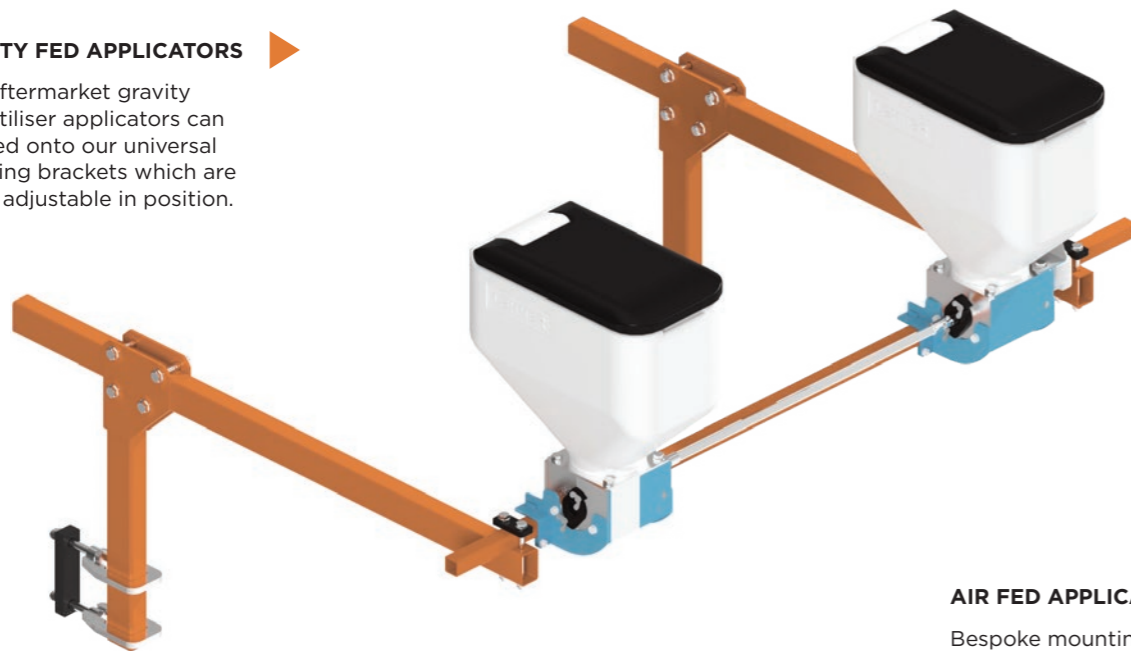

AIR FED APPLICATORS

Bespoke mounting system are available for air driven applicators including access platforms for safe filling.



GRAVITY FED APPLICATOR



AIR FED APPLICATOR

TECHNICAL SPECIFICATION

	HDX
HOPPER CAPACITY (L)	16 litres per hopper
OUTLETS PER METER	2-9
APPROX ROW UNIT WEIGHT (KG)	50kg
ROW UNIT LENGTH	1000mm
DEPTH CONTROL RANGE	90mm
COVERER TYPE	Tine rake
LINES PER ROW	1-6+

KEY LAYOUT TERMINOLOGY

KEY

- a Row Distance
- b Line Distance
- c Bed/Ridge Distance
- d Bed/Ridge Height
- e Bed/Ridge Top Width
- f Tyre Width
- g Track Width

NUMBER OF ROWS / NUMBER OF LINES

8 Rows, 1 Line Per Row



3 Rows Per Bed, 2 Lines Per Row



RIDGE DIMENSIONS



BED DIMENSIONS

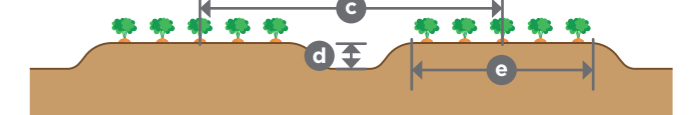

WHEEL TRACK / WIDTH

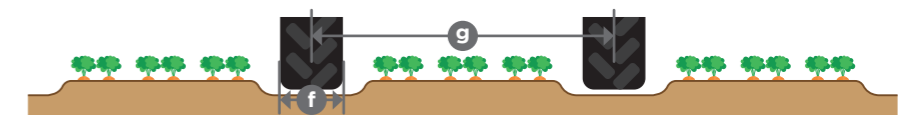
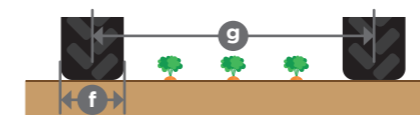



Stanhay leads the world in the design and manufacture of precision seed drills for every kind of crop. Our reputation is built on innovation, quality and performance that delivers the results growers expect.



BCS House, Pinfold Road, Bourne, PE10 9HT, UK
T: +44 (0)1778 392 303 E: info@stanhay.com
www.stanhay.com